



Taylor Valve
Technology

8200/8300 SERIES Safety Relief Valves

Unique.

Precise.

Quality.

Reliable.

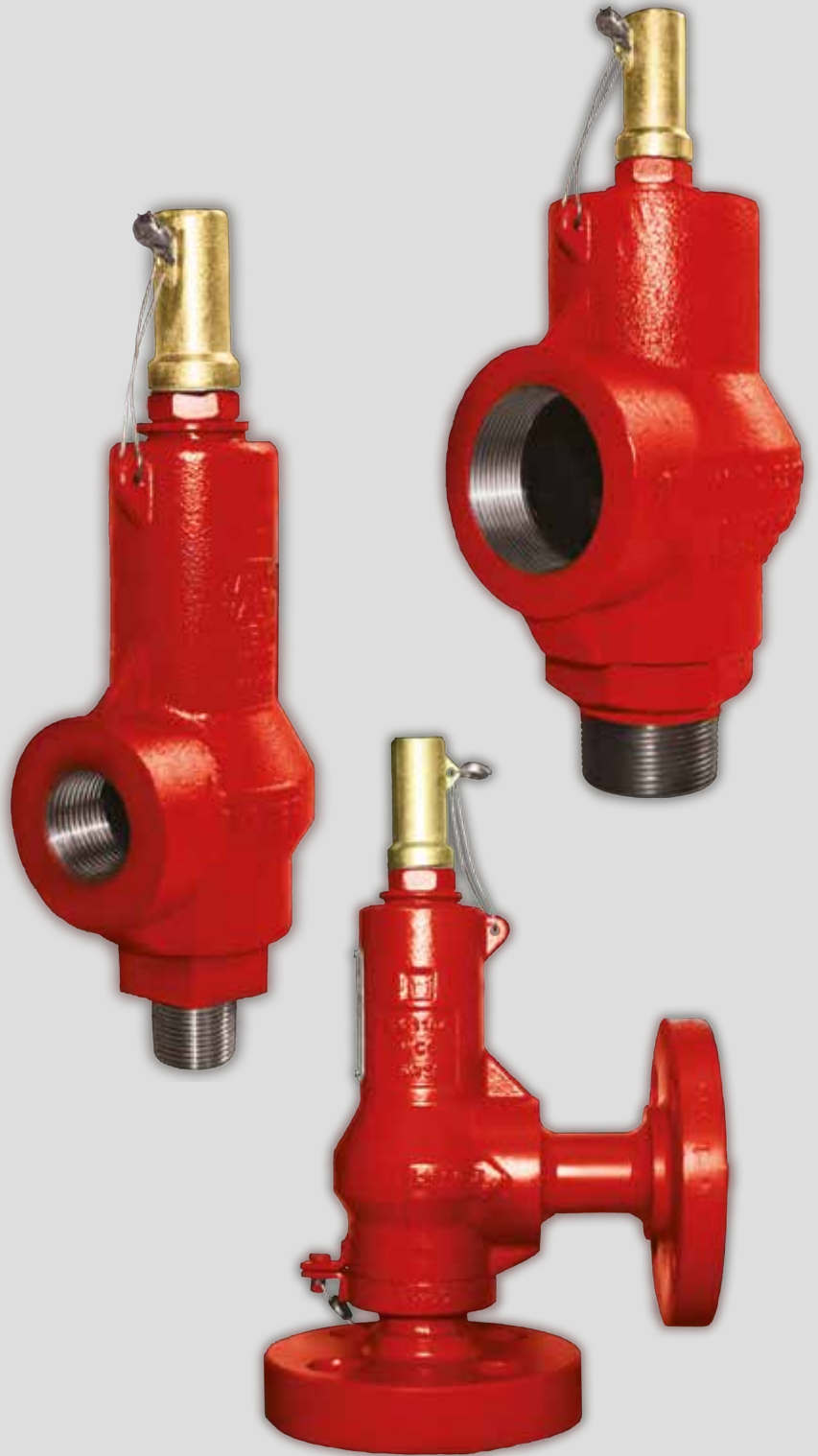

SINCE 1958



Table of Contents

Overview

Bill of Materials	3
-------------------------	---

Specifications

1" 8200 Valve	4
---------------------	---

2" 8200 Valve	5
---------------------	---

3" 8300 Valve	6
---------------------	---

Options & Repair Parts	7
------------------------------	---

Flow Capacity	8
---------------------	---

Ordering

Part Numbering system	10
-----------------------------	----

Bill of Materials & Elastomers Chart

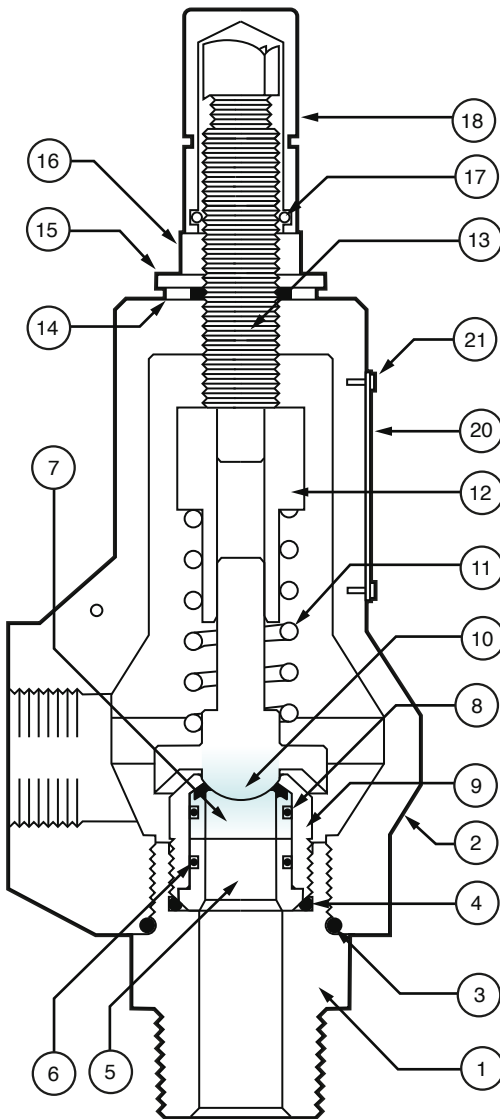

BILL OF MATERIALS

ITEM NO	PART	STANDARD APPLICATION		NACE APPLICATION	
		CARBON STEEL	STAINLESS STEEL	CARBON STEEL	STAINLESS STEEL
1	Seat Frame	1018/1020 CS A108*/A105	316 SS SA479/SA 182	1018/1020 CS A108*/A105	316 SS SA479/SA 182
2	Body	SA216 GR WCC	SA351 CF8M	SA216 GR WCC	SA351 CF8M
3	O-Ring	see Elastomers Chart	see Elastomers Chart	see Elastomers Chart	see Elastomers Chart
4	O-Ring	see Elastomers Chart	see Elastomers Chart	see Elastomers Chart	see Elastomers Chart
5	Insert Holder	304 SS SA479	304 SS SA479	316 SS SA479	316 SS SA479
6	O-Ring	see Elastomers Chart	see Elastomers Chart	see Elastomers Chart	see Elastomers Chart
7	Seat Insert	see Elastomers Chart	see Elastomers Chart	see Elastomers Chart	see Elastomers Chart
8	O-Ring	see Elastomers Chart	see Elastomers Chart	see Elastomers Chart	see Elastomers Chart
9	Seat Body	17-4 PH SS SA564H900	17-4 PH SS SA564H900	316SS SA479 / 17-4 SS SA564 H1150M	316SS SA479 / 17-4 SA564 H1150M
10 ¹	Disc	17-4 PH SS SA564H900	17-4 PH SS SA564H900	316SS SA479 / 17-4 SS H1150M SA564	316SS SA479 / 17-4 SS H1150M SA564
11	Spring	17-7 SS	17-7 SS	316SS or Inconel x750	316SS or Inconel x750
12	Spring Keeper	303 SS SA479	303 SS SA479	303 SS SA479	303 SS SA479
13 ¹	Adjustment Screw	1018 CS	304SS SA240	1018 CS	304SS SA240
14	Thread Seal	BUNA STEEL	BUNA / STEEL	BUNA/STEEL	BUNA/STEEL
15	Flat Washer	CS ANSI B18.22.1	SS ANSI B18.22.1	CS ANSI B18.22.1	SS ANSI B18.22.1
16	Jam Nut	CS ANSI B18.22.2	SS ANSI B18.22.2	CS ANSI B18.22.2	SS ANSI B18.22.2
17 ¹	O-Ring	PC BUNA	PC BUNA	PC BUNA	PC BUNA
18 ¹	CAP	ZINC PLATED CS	316SST	ZINC PLATED CS	316SST
19 ²	Lead Seal Wire	SS	SS	SS	SS
20	Data Label	18-8 SS	18-8 SS	18-8 SS	18-8 SS
21	Drive Screws	18-8 SS	18-8 SS	18-8 SS	18-8 SS

*Alternate CS to SA105 used for pressure above 1440 PSIG.
¹ These parts are replaced with Lift Lever option.
² These parts are not shown

ELASTOMERS CHART

MATERIAL	DUROMETER	TEMP.		PRESSURE		APPLICATIONS
		MIN	MAX	MIN	MAX	
FKM	90	-15	400	50	2000	Hydrocarbons, H2S, Mineral Oil/Grease, Silicone Oil/Grease, Chlorinated Hydrocarbons, Fuels
	50	-15	400	15	150	
HNBR	80	-25	325	15	2000	Hydrocarbons, CO2, H2S, Dilute Acids, Water and Steam Less than 300°F
EPDM	80	-70	250	15	2000	Glycols, Organic Acids, Inorganic Acids, Hydraulic Fluids, Solvents
PTFE	-	-420	450	250	2000	Cryogenics, Strong Acids, Amines
PC BUNA	90	-30	250	15	2000	Hydrocarbons, CO2, Dilute Acids, Water, H2S
PEEK		-60	450	1800	5000	Dilute acids, Glycol, Methanol, Aldehyds, Esthers, Water

NOTE: Taylor Valve reserves the right to change product designs and specifications without notice.

1" 8200 Valve

1" FLANGED CONNECTIONS

1" FLANGED VALVE

Flanges are Locked in place

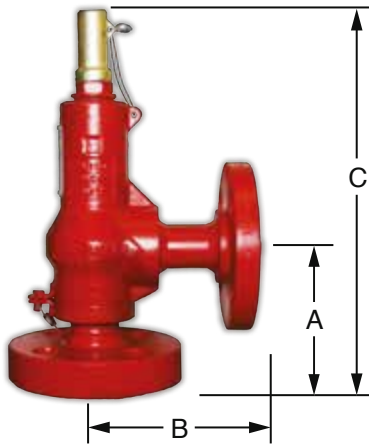

1" THREADED VALVE

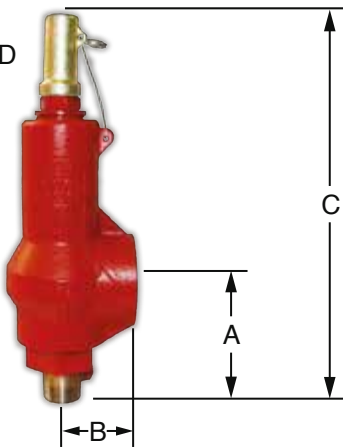

ORIFICE	INLET x OUTLET (inches)	AVAILABLE FLANGE CLASSES INLET x OUTLET	DIMENSIONS (in)		
			A	B	C
D & E	1/2 x 1	150 x 150	4-1/8	4-1/2	10-15/16
		300 x 150	4-1/8	4-1/2	10-15/16
		600 x 150	4-1/8	4-1/2	10-15/16
		900 / 1500 x 300	4-1/8	4-1/2	10-15/16
	3/4 x 1	150 x 150	4-1/8	4-1/2	10-15/16
		300 x 150	4-1/8	4-1/2	10-15/16
		600 x 150	4-1/8	4-1/2	10-15/16
		900 / 1500 x 300	4-1/8	4-1/2	10-15/16
	1 x 1	150 x 150	4-1/8	4-1/2	10-15/16
		300 x 150	4-1/8	4-1/2	10-15/16
		600 x 150	4-1/8	4-1/2	10-15/16
		900 / 1500 x 300	4-1/2	4-1/2	11-5/16
1 x 1-1/2	150 x 150	4-1/8	4-3/4	10-15/16	
	300 x 150	4-1/8	4-3/4	10-15/16	
	600 x 150	4-1/8	4-3/4	10-15/16	
	900 / 1500 x 300	4-1/2	4 3/4	11-5/16	
1 x 2	150 x 150*	4-1/8	4-1/2	10-15/16	
	300 x 150*	4-1/8	4-1/2	10-15/16	
	600 x 150*	4-1/8	4-1/2	10-15/16	
	900 / 1500 x 300	4-1/2	4-1/2	11-5/16	
1-1/2 x 2	150 x 150	4-7/8	4-3/4	11-11/16	
	300 x 150	4-7/8	4-3/4	11-11/16	
	600 x 150	4-7/8	5-1/2	11-11/16	
	900 / 1500 x 300*	4-1/8	5-1/2	10-15/16	
F	1 x 1-1/2	150 x 150	4-1/8	4-3/4	10-15/16
		300 x 150	4-1/8	4-3/4	10-15/16
		600 x 150	4-1/8	4-3/4	10-15/16
		900 / 1500 x 300	4-1/8	4-3/4	11-5/16
	1 x 2	150 x 150	4-1/8	4-1/2	10-15/16
		300 x 150	4-1/8	4-1/2	10-15/16
		600 x 150	4-1/8	4-1/2	10-15/16
		900 / 1500 x 300	4-1/2	4-1/2	11-5/16
	1-1/2 x 2	150 x 150*	4-7/8	4-3/4	11-11/16
		300 x 150*	4-7/8	4-3/4	11-11/16
		600 x 150*	4-7/8	6	11-11/16
		900/1500 x 300	4-7/8	6-1/2	11-11/16

* - Denotes dimension in accordance to API 526

1" THREADED CONNECTIONS

ORIFICE	ORIFICE AREA (sq. in)	PRESSURE RANGES (psig)	Kd		CONNECTIONS (inches)		DIMENSIONS (inches)			WEIGHT (lbs)
			GAS	LIQUID	INLET (MALE)	OUTLET (FEMALE)	A	B	C	
D	0.128	15 - 5000	0.838	0.62 ¹	1/2	1	3-1/2	1-7/8	10-1/8	6
					3/4, 1	1, 1-1/4, 1-1/2	3-1/4	1-7/8	9-13/16	
E	0.212	15 - 2500	0.791	0.656	1/2	1	3-1/2	1-7/8	10-1/8	6
					3/4, 1	1, 1-1/4, 1-1/2	3-1/4	1-7/8	9-13/16	
F	0.357	15 - 1500	0.836	0.62 ¹	3/4, 1	1-1/4, 1-1/2	3-1/4	1-7/8	9-13/16	6

NOTE: Female Inlet Connections Available Upon Request. ¹Not ASME Certified.

2" 8200 Valve

FLANGED & THREADED

The Taylor 2" 8200 Safety Relief Valve is an excellent choice for Air, Gas or Liquid relief applications, including Compressors, Separators, Heater Treaters, Free Water Knockouts, Scrubbers, Dehydrators, Thermal Relief, Gas Production Units, Transmission and Gathering Lines, Chemical Plants, Refineries, Meter Runs, Gas Plants and other Industrial Applications.

2" FLANGED CONNECTIONS

ORIFICE	INLET x OUTLET (inches)	AVAILABLE FLANGE CLASSES INLET x OUTLET	DIMENSIONS (in)			C ² (EXT. BODY) ₂
			A	B	C	
G & H	1-1/2 x 2	150 x 150	4-7/8	4-7/8	11-1/8	12-11/16
		300 x 150	4-7/8	4-7/8	11-1/8	12-11/16
		600 x 150	4-7/8	4-7/8	11-1/8	12-11/16
		900 / 1500 x 300	6-1/8	6-3/4	12-3/8	13-15/16
	1-1/2 x 2-1/2	150 x 150	4-7/8	4-7/8	11-1/8	12-11/16
		300 x 150	4-7/8	4-7/8	11-1/8	12-11/16
		600 x 150	4-7/8	4-7/8	11-1/8	12-11/16
		900 / 1500 x 300	5-3/4	6	12	13-9/16
	1-1/2 x 3	(G)150 x 150*	4-7/8	4-3/4	11-1/8	12-15/16
		(H)150 x 150*	5-1/8	4-7/8	11-3/8	12-15/16
		(G)300 x 150*	4-7/8	6	11-1/8	12-15/16
		(H)300 x 150*	5-1/8	4-7/8	11-3/8	12-15/16
		(G)600 x 150*	4-7/8	6	11-1/8	12-15/16
		(G)900 / 1500 x 300*	4-7/8	6-1/2	11-1/8	12-15/16
	2 x 2	150 x 150	5-1/8	4-7/8	11-3/8	12-15/16
		300 x 150	5-1/8	4-7/8	11-3/8	12-15/16
		600 x 150	5-1/8	6	11-3/8	12-15/16
		900 / 1500 x 300	6-1/16	6-3/8	12-5/16	13-7/8
	2 x 2-1/2	150 x 150	5-1/8	4-7/8	11-3/8	12-15/16
		300 x 150	5-1/8	6	12-5/16	12-15/16
		600 x 150	6-1/16	6	12-5/16	13-7/8
		900 / 1500 x 300	6-1/16	6-3/8	12-5/16	13-7/8
	2 x 3	150 x 150	6-1/16	4-3/4	12-5/16	13-7/8
		(H)300 x 150*	5-1/8	4-7/8	11-3/8	12-15/16
(H)600 x 150*		6-1/16	6-3/8	12-5/16	13-7/8	
(G)900 / 1500 x 300*		6-1/8	6-3/4	12-3/8	13-15/16	
(H)900 / 1500 x 300*		6-1/16	6-3/8	12-5/16	13-7/8	

* - Denotes dimension in accordance to API 526; ² C² (EXT. BODY) used on all H orifice valves.

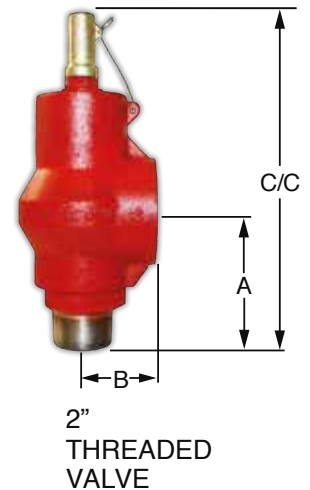
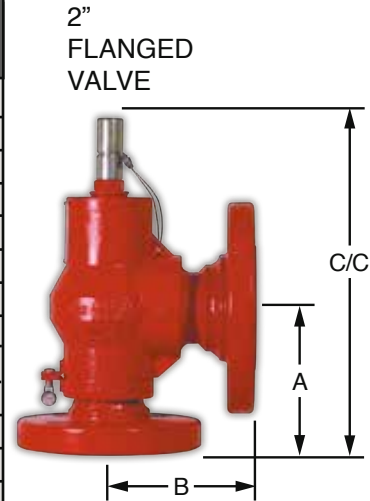

2" THREADED CONNECTIONS

ORIFICE	ORIFICE AREA (sq. in)	PRESSURE RANGES (psig)	Kd		CONNECTIONS (inches)		DIMENSIONS (inches)			C ² (EXTENDED BODY)	WEIGHT (lbs)
			GAS	LIQUID	INLET (MALE)	OUTLET (FEMALE)	A	B	C		
G	0.472	15 - 2000	0.786	0.588	1-1/2, 2, 2-1/2	2, 2-1/2	4-1/4	2-5/16	10-9/16	-	11
H	0.913	15 - 1500	0.837	0.62 ¹	1-1/2, 2, 2-1/2	2, 2-1/2	4-1/4	2-5/16	-	11-3/4	11

¹ Not ASME Certified; ² C² (Extended Body) used on all H orifice Valves

3" 8300 Valve

FLANGED & THREADED

The Taylor 3" 8300 Safety Relief Valve is an excellent choice for Air, Gas or Liquid relief applications, including Compressors, Separators, Heater Treaters, Free Water Knockouts, Scrubbers, Dehydrators, Thermal Relief, Gas Production Units, Transmission and Gathering Lines, Chemical Plants, Refineries, Meter Runs, Gas Plants and other Industrial Applications.

3" FLANGED VALVE

Flanges are Locked in place

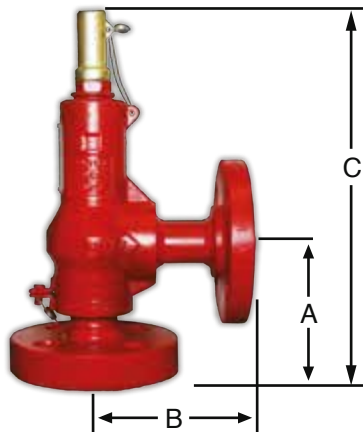

3" THREADED VALVE

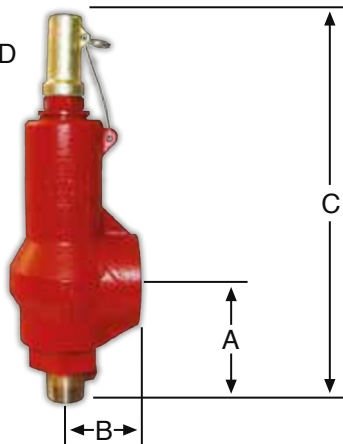

3" FLANGED CONNECTIONS

ORIFICE	INLET x OUTLET (inches)	AVAILABLE FLANGE CLASSES INLET x OUTLET	A (in)	B (in)	C (in)
J	2 x 3	(J)150 x 150**	5-3/8	5-7/8	16-1/4
		(J)300 x 150**	5-3/8	5-7/8	15-1/4
		600 x 150	6-7/8	6-3/4	17-3/4
	2-1/2 x 3	150 x 150	6-1/16	5-7/8	16-15/16
		300 x 150	6-1/16	5-7/8	16-15/16
		600 x 150	6-3/8	6-3/8	17-1/4
3 x 3	150 x 150	6-1/8	6-3/8	17	
	300 x 150	6-1/8	6-3/8	17	
	600 x 150	7-1/8	6-3/4	18	
K	3 x 4	(J)150 x 150	7-1/4	7-1/8	18-1/8
		(K)150 x 150*	6-1/8	6-3/8	17
		(J)300 x 150*	7-1/4	7-1/8	18-1/8
	4 x 4	(K)300 x 150*	6-1/8	6-3/8	17
		600 x 150*	7-1/4	7-1/8	18-1/8
		150 x 150	6-3/8	7-1/8	17-1/4
4 x 4	300 x 150	6-3/8	7-1/8	17-1/4	
	600 x 150	6-3/8	7-1/8	17-1/4	

* - Denotes dimension in accordance to API 526
 ** - Dimensions not to API 526

3" THREADED CONNECTIONS

ORIFICE	ORIFICE AREA (sq. in)	PRESSURE RANGES (psig)	Kd		CONNECTIONS (inches)		DIMENSIONS (inches)			WEIGHT (lbs)
			GAS	LIQUID	INLET (MALE)	OUTLET (FEMALE)	A	B	C	
J	1.431	15 - 1000	0.808	0.637	2, 2-1/2, 3	3	5-15/16	3-5/8	15-7/8	35
K	2.138	15 - 500	0.741	0.621	2-1/2, 3	3	5-15/16	3-5/8	15-7/8	35

¹Not ASME Certified

Options & Repair Parts

1" 8200 VALVE REPAIR PARTS

ORIFICE	PARTS	QTY.
D	O-RING 2-014	2
	O-RING 2-012	1
	O-RING 2-016	1
	THREAD SEAL	1
	INSERT HOLDER	1
	SEAT HOLDER	1
	DISC	1
E	SEAT INSERT	1
	O-RING 2-017	2
	O-RING 2-012	1
	O-RING 2-016	1
	THREAD SEAL	1
	INSERT HOLDER	1
	SEAT HOLDER	1
F	DISC	1
	SEAT INSERT	1
	O-RING 2-018	2
	O-RING 2-014	1
	O-RING 2-020	1
	THREAD SEAL	1
	INSERT HOLDER	1
F	SEAT HOLDER	1
	DISC	1
	SEAT INSERT	1

3" 8300 VALVE REPAIR PARTS

ORIFICE	PARTS	QTY.
J	O-RING 2-223	2
	O-RING 2-236	1
	O-RING 2-232	1
	THREAD SEAL	1
	INSERT HOLDER	1
	SEAT HOLDER	1
	DISC	1
K	SEAT INSERT	1
	O-RING 2-225	2
	O-RING 2-236	1
	O-RING 2-232	1
	THREAD SEAL	1
	INSERT HOLDER	1
	SEAT HOLDER	1
K	DISC	1
	SEAT INSERT	1

RELIEF VALVE OPTIONS

LIFT LEVER OPTION 1/4" FNPT TAP
ON SEAT FRAME OPTION

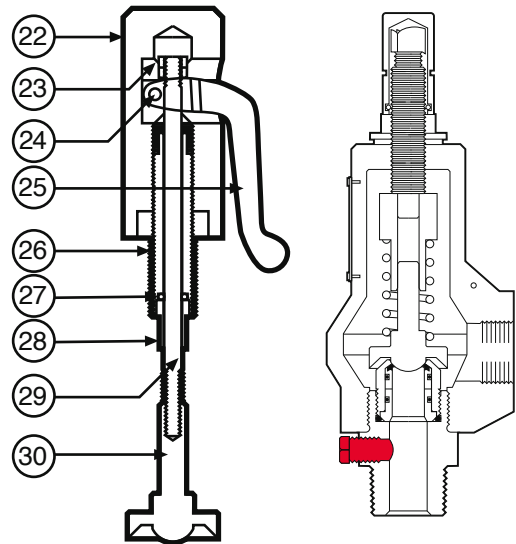

2" 8200 VALVE REPAIR PARTS

ORIFICE	PARTS	QTY.
G	O-RING 2-125	2
	O-RING 2-223	1
	O-RING 2-226	1
	THREAD SEAL	1
	INSERT HOLDER	1
	SEAT HOLDER	1
	DISC	1
H	SEAT INSERT	1
	O-RING 2-125	2
	O-RING 2-225	1
	O-RING 2-226	1
	THREAD SEAL	1
	INSERT HOLDER	1
	SEAT HOLDER	1
H	DISC	1
	SEAT INSERT	1

LIFT LEVER OPTION BILL OF MATERIALS

ITEM NO.	PART	STANDARD APPLICATION		NACE APPLICATION	
		CARBON STEEL	STAINLESS STEEL	CARBON STEEL	STAINLESS STEEL
22	Lift Level Cap	304 SS SA479	304 SS SA479	304 SS SA479	304 SS SA479
23	Lock Nut	STEEL	STEEL	STEEL	STEEL
24	Clevis Pin	316 SS SA479	316 SS SA479	316 SS SA479	316 SS SA479
25	Lift Handle	ALUMINUM BRONZE	ALUMINUM BRONZE	ALUMINUM BRONZE	ALUMINUM BRONZE
26	Adjustment Screw	17-4PH SS H900 SA564	17-4PH SS H900 SA564	17-4PH SS H900 SA564	17-4PH SS H900 SA564
27	O-Ring	See pg.2 Elast. Chart	See pg.2 Elast. Chart	See pg.2 Elast. Chart	See pg.2 Elast. Chart
28	O-Ring Follower	304 SS SA479	304 SS SA479	304 SS SA479	304 SS SA479
29	Stem	304 SS SA479	304 SS SA479	304 SS SA479	304 SS SA479
30	Disc	17-4 H900 SS SA564	17-4 H900 SS SA564	17-4PH SS H1150 SA564	17-4PH SS H1150 SA564

Flow Capacity

WHERE:

- V = Volumetric Flow Rate, SCFM
- W = Mass Flowrate, lb/hr
- Q = Volumetric Flow Rate, GPM
- C = constant for Gas or Vapor based on ratio of specific heats, k (Cp/Cv) (see chart at right)
- A = orifice throat area, square inches
- K_d = Rated Coefficient of Discharge
- M = molecular weight (see chart at right)
- P1 = (stamped set pressure + 3 psi or 10%, whichever is greater) + 14.7 psia
- P_d = pressure at the discharge of the valve, psia
- T = absolute temperature at inlet, R (degrees Fahrenheit + 460)
- slope = value determined by the ASME through testing at the National Board Test Lab, Columbus, OH; for Air and Gas service, SCFM/psia
- F = (value determined by the ASME through testing at the National Board Test Lab, Columbus, OH; for Liquid service, GPM/ sqrt(PSID)
- G = Specific Gravity
- Z = compressibility factor for gas or vapor, (=1 if unknown)
- K_v = Viscosity Correction Factor calculated from Reynold's Number and Viscosity (=1 if unknown)

FLOW CAPACITY CHARTS & FORMULAS

To determine the relieving capacity which should appear on a valve for a given pressure, use either the Coefficient Method or Slope Method.

COEFFICIENT METHOD

For Gas/Vapor, lb/hr: $W = ACK_d P_1 \sqrt{\frac{M}{T}}$

For Gas/Vapor, SCFM: $V = 6.32 CK_d P_1 A \frac{1}{\sqrt{TMZ}}$

For Air (ASME Capacity), SCFM: $V = 18.331 \cdot K_d A P_1$

For Liquid, GPM: $Q = 38 \cdot AK_d K_v \sqrt{\frac{P_1 - P_2}{G}}$

For Water(ASME Capacity), GPM: $Q = 38 AK_d \sqrt{P_1 - P_2}$

SLOPE METHOD

For Air, SCFM: $V = \text{slope} \cdot P_1$

For Water, GPM: $Q = F \sqrt{P_1 - P_2}$

MOLECULAR WEIGHT AND VALUES OF "C" FOR GASES

GAS	M	C	GAS	M	C
AIR	28.97	356	HYDROGEN	2.02	356
ACETYLENE	26.04	345	HYDROGEN SULFIDE	34.08	348
AMMONIA	17.03	351	METHANE	16.04	346
BUTANE	58.12	324	METHYL CHLORIDE	50.48	337
CARBON DIOXIDE	44.01	345	NATURAL GAS (0.6)	17.40	344
CHLORINE	70.91	352	NITROGEN	28.02	356
ETHANE	30.07	339	OXYGEN	32.00	356
ETHYLENE	28.05	337	PROPANE	44.09	331
FREON 22	86.48	355	SULFUR DIOXIDE	64.06	342

AIR FLOW CAPACITY VS. PRESSURE (CONDITIONS SHOWN BELOW)								
ORIFICE	D	E - 1/2" MNPT	E	F	G	H	J	K
BODY SIZE (IN.)	1	1	1	1	2	2	3	3
ORIFICE DIA. (IN.)	0.404	0.52	0.52	0.674	0.775	1.078	1.35	1.65
ORIFICE AREA (SQ.IN.)	0.128	0.212	0.212	0.357	0.472	0.913	1.431	2.138
SLOPE	1.97	3.08	3.24	5.465	6.8	14	21.2	29.03
Kd FACTOR	0.838	0.791	0.832	0.836	0.786	0.837	0.808	0.741
ASME CODE	YES	YES	YES	YES	YES	YES	YES	YES
SET PRESSURE (PSIG)	CAPACITY IN SCFM. OVERPRESSURE = 110% OR 3 PSI, WHICHEVER IS GREATER							
15	64	100	105	178	222	457	693	944
20	74	116	122	206	256	527	799	1094
25	84	131	138	233	290	597	905	1239
30	93	146	154	260	324	667	1011	1384
50	137	214	225	380	473	975	1477	2023
100	245	384	404	681	847	1745	2643	3620
150	354	553	582	982	1221	2515	3809	5216
200	462	722	760	1282	1595	3285	4975	6813
250	570	892	938	1583	1969	4055	6141	8409
300	679	1061	1116	1883	2343	4825	7307	10006
400	895	1400	1475	2484	3091	6365	9639	13199
500	1112	1739	1829	3086	3839	7905	11971	16393
600	1329	2078	2186	3687	4587	9445	14303	14303
700	1545	2416	2542	4288	5335	10985	16635	16635
900	1979	3094	3255	5490	6831	14065	21290	21299
1000	2195	3433	3611	6091	7574	15605	23637	23631
1500	3279	5127	5393	9097	11319	23305		25791
1750	3821	5974	6284		13189			
2000	4362	6821	7175		15059			
2500	5446	8515	8957					
3000	6529							
4000	8646							
4500	9780							
5000	10863							
CONDITIONS								
Temp. (°F)	Baro. Press.	SG	Cp/Cv	Comp. Factor	MW	Density	Gas Constant	
60	14.7	1	1.4	1	28.98	0.0764	356	

WATER FLOW CAPACITY VS. PRESSURE (CONDITIONS SHOWN BELOW)								
ORIFICE	D	E - 1/2" MNPT	E	F	G	H	J	K
BODY SIZE (IN.)	1	1	1	1	2	2	3	3
ORIFICE DIA. (IN.)	0.404	0.52	0.52	0.674	0.775	1.078	1.35	1.65
ORIFICE AREA (SQ.IN.)	0.128	0.212	0.212	0.357	0.472	0.913	1.431	2.138
FLOW FACTOR	3.02	5.29	5.29	8.41	10.54	21.5	34.62	50.95
Kd FACTOR	0.62	0.656	0.656	0.62	0.588	0.62	0.637	0.62
ASME CODE	NO	YES	YES	NO	YES	NO	YES	NO
SET PRESSURE (PSIG)	CAPACITY IN GPM. OVERPRESSURE = 110% OR 3 PSI, WHICHEVER IS GREATER							
15	13	22	22	35	44	91	146	213
20	14	25	25	40	50	103	166	241
25	16	27	28	44	55	113	183	266
30	17	30	30	48	60	123	198	289
50	22	39	39	62	78	159	256	373
100	32	55	55	88	110	225	363	528
150	39	67	68	108	135	276	444	647
200	45	78	78	124	156	318	513	747
250	50	87	88	139	174	356	574	835
300	55	96	96	152	191	390	628	915
400	63	110	111	176	221	450	726	1056
500	71	124	124	197	247	504	811	1181
600	77	135	136	216	270	552	890	
700	84	146	147	233	292	596	960	
900	95	166	166	264	331	676	1089	
1000	100	175	175	278	349	713	1148	
1500	122	214	215	341	428	873		
1750	132	232	232		462			
2000	141	248	248		494			
2500	158	277	277					
3000	173							
4000	200							
4500	212							
5000	224							
CONDITIONS								
Temp. (°F)	Baro. Pressure	SG	Back Pressure	Kv	MW			
70	14.7	1	0	1	17.39			

Part Numbering System

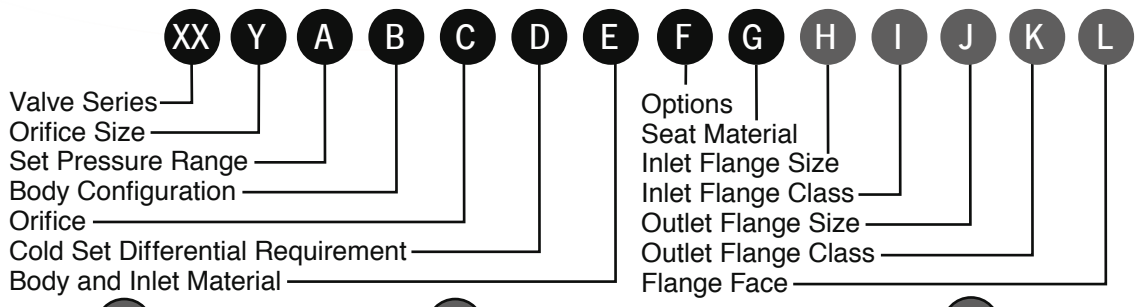

XX

VALVE SERIES	
CODE	SERIES
82	8200
83	8300

Y

ORIFICE SIZE	
CODE	SIZE (IN)
D	1
E	1
F	1
G	2
H	2
J	3
K	3

A

ORIFICE	SET PRESSURE RANGE			
	STANDARD SERVICE		NACE SERVICE	
	CODE	RANGE	CODE	RANGE
G	2	15-25	2	15-30
	3	26-60	3	31-60
	4	61-110	4	61-130
	5	111-170	5	131-200
	6	171-240	6	201-300
	7	241-310	7	301-450
	8	311-475	8	451-650
	9	476-520	9	651-900
	0	521-650	0	901-1200
	10	651-900	10	1201-1600
	11	901-1200	11	1601-2000
	12	1201-1600		
	13	1601-2000		
H	1	15-30	1	15-30
	2	31-50	2	31-50
	3	51-75	3	51-75
	4	76-110	4	76-110
	5	111-180	5	111-180
	6	181-270	6	181-270
	7	271-400	7	271-400
	8	401-610	8	401-610
	9	611-800	9	611-800
	0	801-1050	0	801-1050
	10	1051-1200	10	1051-1200
	11	1201-1500	11	1201-1500
J	2	15-35	2	15-35
	3	36-60	3	36-60
	4	61-90	4	61-90
	5	91-140	5	91-140
	6	141-250	6	141-250
	7	251-380	7	251-380
	8	381-500	8	381-500
	9	501-620	9	501-620
	0	621-775	0	621-775
	10	776-1000	10	776-1000
	K	1	10-24	1
2		25-40	2	25-40
3		41-79	3	41-79
4		80-107	4	71-107
5		108-220	5	108-220
6		221-250	6	221-250
7		251-325	7	251-325
8		326-400	8	326-400
9		401-500	9	401-500

A

ORIFICE	SET PRESSURE RANGE			
	STANDARD SERVICE		NACE SERVICE	
	CODE	RANGE	CODE	RANGE
D	1	15-40	1	15-40
	2	41-100	2	41-100
	3	101-215	3	101-215
	4	216-350	4	216-350
	5	351-750	5	351-750
	6	751-1000	6	751-1000
	7	1001-1800	7	1001-1800
	8	1801-3700	8	1801-3700
	9	3701-5000		
E	1	15-25	1	15-25
	2	26-50	2	26-50
	3	51-100	3	51-100
	4	101-225	4	101-200
	5	226-450	5	201-350
	6	451-650	6	351-700
	7	651-1200	7	701-1200
	8	1201-1600	8	1201-1600
	9	1601-2100	9	1601-2100
	0	2101-2500	0	2101-2500
F	1	15-35	1	15-35
	2	36-75	2	36-75
	3	76-140	3	76-140
	4	141-250	4	141-290
	5	251-375	5	291-440
	6	376-445	6	441-650
	7	446-650	7	651-920
	8	651-920	8	921-1500
	9	921-1500		

*For set pressures below 15psig please contact Taylor Valve Technology for available valve options.

B BODY CONFIGURATION			
SERIES	CODE	INLET x OUTLET (INCHES)	ORIFICES (AVAILABLE)
8200 1"	0	1/2 MNPT x 1 FNPT (UV)	D & E
	1	1/2 FNPT x 1 FNPT (NO UV)	D & E
	2	3/4 MNPT x 1 FNPT	D & E
	3	1 MNPT x 1 FNPT	D & E
	4	3/4 FNPT x 1 FNPT	D & E
	5	3/4 MNPT x 1-1/2 FNPT	D, E & F
	6	1 MNPT x 1-1/2 FNPT	D, E & F
	7	FLANGED	D, E & F
	8	1 FNPT x 1-1/2 FNPT	D, E & F
	9	1 FNPT x 1 FNPT	D & E
	10	1 MNPT x 1-1/4 FNPT	D & E
8200 2"	1	2 MNPT x 2-1/2 FNPT	G & H
	3	1-1/2 FNPT X 2 FNPT	G & H
	4	1/4" FNPT X 2 FNPT	G
	5	1-1/2 MNPT X 2 FNPT	G & H
	6	2 MNPT X 2 FNPT	G & H
8300 3"	7	2 FNPT X 2 FNPT	G & H
	8	FLANGED	G & H
	2	2 MNPT X 3 FNPT	J
	3	3 FNPT x 3 FNPT	J
	4	2-1/2 MNPT X 3 FNPT	J & K
	7	3 MNPT X 3 FNPT	J & K
	8	FLANGED	J
	9	FLANGED	K

H INLET FLANGE SIZE		
SERIES	CODE	PIPE SIZE (in)
8200 1"	9*	1/2
	0*	3/2
	1	1
	7	1-1/4
8200 2"	3	1-1/2
	7	1-1/4
	4	2
	5	2-1/2
8300 3"	6	3
	4	2
	5	2-1/2

*D&E ORIFICE SIZE ONLY

I INLET FLANGE CLASS	
CODE	CLASS
0	150
1	300
3	600
4	900
5	1500

C ORIFICE CODE	
CODE	ORIFICE
1	J
2	K
4	D
5	E - 1"
	G - 2"
6	F
7	H

D COLD SET DIFFERENTIAL REQUIREMENT	
CODE	TEMPERATURE
1	AMBIENT

J OUTLET FLANGE SIZE		
SERIES	CODE	PIPE SIZE (in)
8200 1"	1*	1
	7	1-1/4
	3	1-1/2
	4	2
8200 2"	7	1-1/4
	3	1-1/2
	4	2
	5	2-1/2
8300 3"	6	3
	4	2
	5	2-1/2
	6	3

*D&E ORIFICE SIZE ONLY

E BODY & INLET MATERIAL	
CODE	MATERIAL
3	CARBON STEEL
5	STAINLESS STEEL
6	CS BODY/SS SEAT FRAME
7	CS BODY/316 INTERNALS
8	SS BODY/316 INTERNALS
9	CS BODY/SS SEAT FRAME/ 316 INTERNALS

F TOP STYLE / OPTIONS	
CODE	SERIES
0	OPEN LL
1	CLOSED TOP
2	1/8 NPT TAP
3	LIFT LEVER (LL)
4	NACE
5	1/4 NPT TAP
6	LL & 1/4 NPT TAP
7	STD/NACE SPRING
8	LL/NACE
9	1/4 TAP/NACE

K OUTLET FLANGE CLASS	
CODE	CLASS
0	150
1	300
3	600
4	900
5	1500

G SEAT / O-RING MATERIAL			
CODE	MATERIAL	CODE	MATERIAL
1	FKM	0	PTFE/Neoprene
2	PTFE/FKM	B	PTFE/PC Buna
3	HNBR	C	PTFE/EPDM
5	PEEK/FKM	D	PTFE/Lo-Temp NBR
7	PC Buna	E	PEEK/PC Buna
9	EPDM	F	PTFE/FFKM
		G	PEEK/FFKM

L FLANGE FACES	
CODE	INLET x OUTLET
0	RFF x RFF
1	RFF x RTJ
2	RTJ x RFF
3	RTJ x RTJ



Taylor Valve Technology
8300 S.W. 8th Street
Oklahoma City, Oklahoma 73128

TEL 405.787.0145

FAX 800.805.3401

WEB www.taylorvalve.com

EMAIL info@taylorvalve.com



Unique.

Precise.

Quality.

Reliable.

